

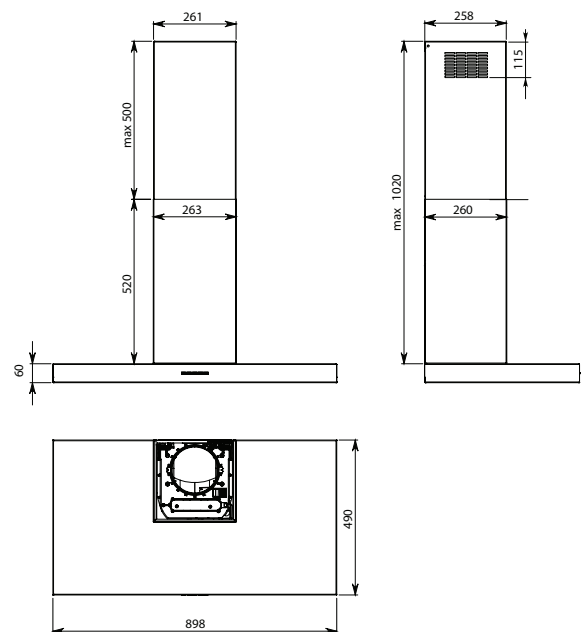

Product Features

<b>Motor Type</b>	On Board Motor
<b>Dimensions</b>	898(W) x 1020(H) x 490(D)mm Suits 75cm-100cm Cooking Surfaces
<b>Filtration Type</b>	Metallic Mesh Filters
<b>Controls</b>	Soft Touch Controls
<b>Lighting</b>	2 x LED
<b>Speed Settings</b>	3 Speed + Boost
<b>Timer Function</b>	15 Min Auto Shut-Off
<b>Ducting</b>	150mm Circular Outlet
<b>Optional Accessories</b>	700mm Wall Flue Extension 1200mm Island Flue Extension
<b>Remote Control</b>	Optional
<b>Grease Filter Alarm</b>	Yes
<b>Dishwasher Safe Filters</b>	Yes
<b>Charcoal Filter</b>	Yes

Dimensioned Drawings



Model Code	Size	Motor Output	Finish
F7PB90B1 •	90cm	800m <sup>3</sup> /hr	Matte Black

Special Order •

## PLANE BLACK

### Version

Island 90 cm - Black - 800  
m<sup>3</sup>/h

### Collection

Design

### EAN code

8034122359885

## MOTOR TECHNICAL SHEET

Motor speed	1	2	3	4
Noise level dB(A) <sub>re1pW-I.E.C.60704-2-13</sub>	49	56	62	68
Capacity (m <sup>3</sup> /h) I.E.C.61591	280	370	480	680
Maximum pressure (Pa)	390	420	480	500
Motor Power (W)	132	153	175	215
Air outlet	150	150	150	150

## CAPACITY / PRESSURE

